

0115 7788 227
info@bem-services.co.uk
www.bem-services.co.uk
Suite 1, No. 11 Salisbury Street, Long Eaton, Derbyshire, NG10 1BA



LAND TO THE REAR OF



Lighting Design Report

2547-RPT-001

Client: Leicester City Council

Date: 16 September 2024

Revision: A

Document Control

Document: Land to the rear of [REDACTED] Lighting Design Report

Project: Land to the rear of [REDACTED]

Project Number: 2547

Document Checking:

Primary Author: [REDACTED]

Contributor: Initialed:

Review By: [REDACTED]

Issue	Date	Status	Checked for Issue
[REDACTED]	[REDACTED]	[REDACTED]	[REDACTED]
[REDACTED]	[REDACTED]	[REDACTED]	[REDACTED]
[REDACTED]	[REDACTED]	[REDACTED]	[REDACTED]
[REDACTED]	[REDACTED]	[REDACTED]	[REDACTED]

CONTENTS

1. Introduction3

2. Setting Out Area.....3

3. Column Locations4

4. Light Fitting Details5

5. Calculations Explaining Lux Levels Achieved.....7

6. Lux Level Contours from DIALux Lighting Simulation 10

7. Light Spill Calculation on Neighbouring House Façades 18

8. Compliance with Bat Regulations..... 24

9. Conclusion..... 25

1. Introduction

This report presents the proposed lighting design for land to the rear of [REDACTED] located at [REDACTED]. The objective of this design is to provide safe, adequate, and compliant lighting for the car park while minimising light pollution to neighbouring properties and ensuring compliance with relevant environmental and planning regulations. The design has been created using [REDACTED] modelling software and is based on the guidelines provided by BS 5489-1:2020, SSL Lighting Handbook 2018, IPL Guidance Note GN 08/23, including those for suburban areas, bat conservation, and light pollution prevention.

2. Setting Out Area

The lighting design ensures that the illuminated area does not exceed the site boundaries significantly, and efforts have been made to reduce light spill into the neighbouring residential properties. The following diagrams show the boundaries and the locations of all key elements, including dwellings, gardens, and roads. The area covered by the lighting design includes the north section of the proposed car park. The boundaries of the site are shown in Figure 1 below.

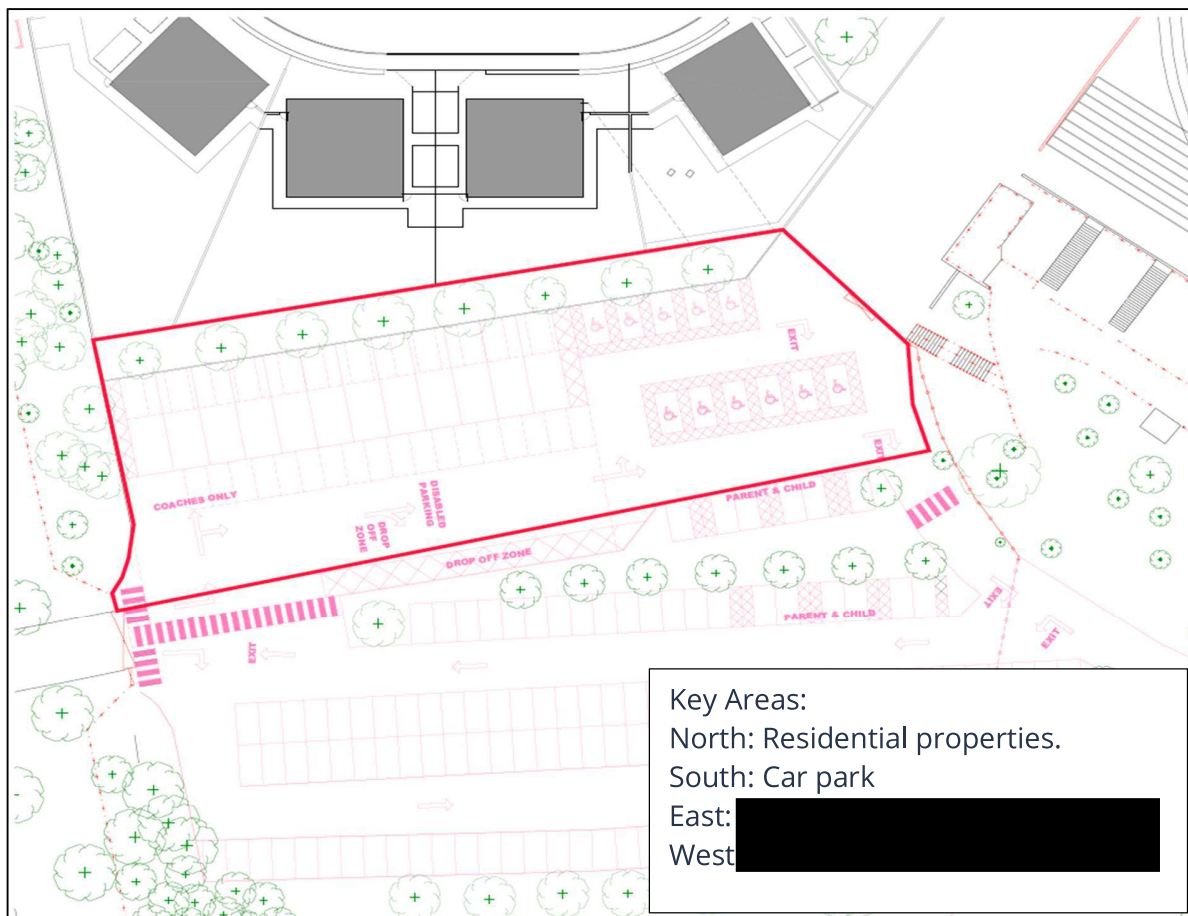

Figure 1. Proposed Site

The existing site is a fenced off area surrounded by trees on one side and fencing on the other three sides, as shown in Figure 2 below.



Figure 2. Existing Site

3. Column Locations

The proposed lighting system includes 3 column lights strategically positioned along the tree canopy located at the north of the car park to provide uniform coverage while minimising obtrusive lighting and sky glow. The specific locations of the lighting columns are shown in the figure below.

The placement of the columns has been carefully considered to ensure even light distribution and minimise light spill, especially near residential areas. The height of the columns is 7m, with adjustable fixtures to allow for precise aiming and control of the light spread.

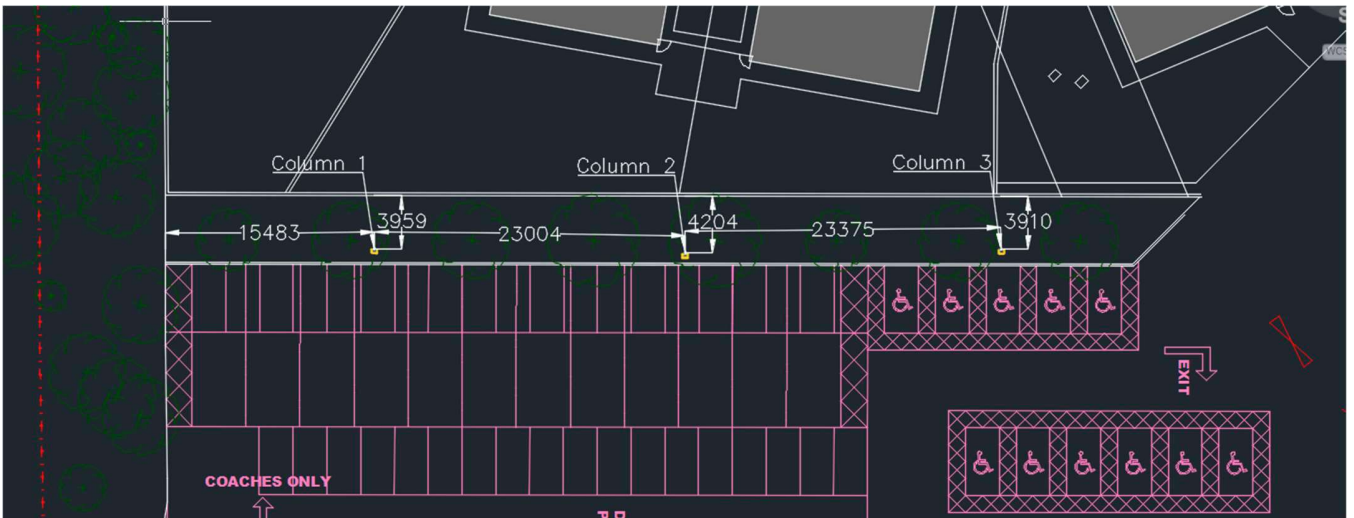

Figure 3. Column Locations

4. Light Fitting Details

Each lighting column is equipped with Dextra OPUS 3XL BAFFLE REAR GY flood light, LED, 4000K, 216W. These fittings have been chosen for their energy efficiency, low glare, and ability to control light spill.

Key details of the light fittings:

Type: LED floodlight.

Power: 216W.

Colour Temperature: 4000K (neutral white)

Beam Angle: Varies

Control Features: Adjustable aiming angles and baffles fitted to reduce light spill

Figure 4 shows the fitting dimensions.

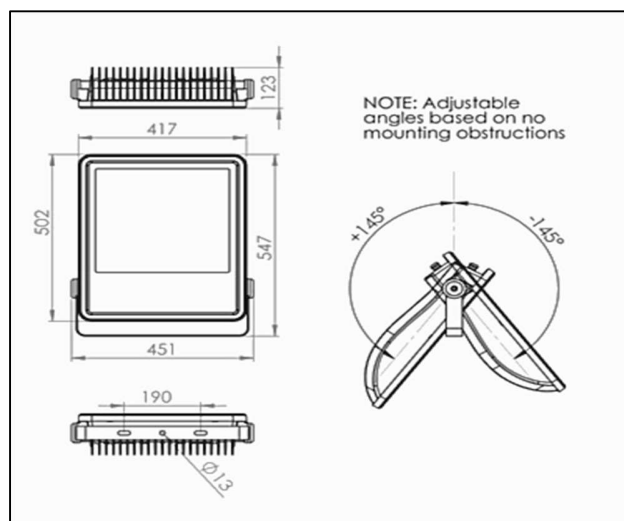

Figure 4. OPUS 3XL Dimensions

The light fitting has a baffle to deflect light forwards, the details of the baffle are shown in figure 5.

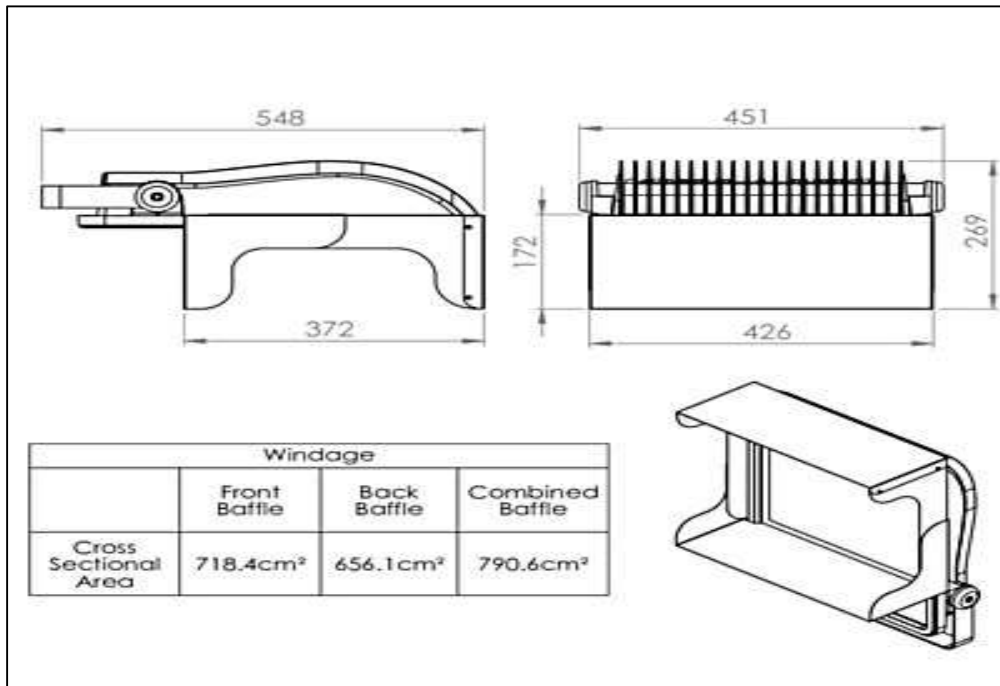

Figure 5. OPUS 3XL Baffle Dimensions

The light fittings are angled downwards by up to 2 degrees to optimise the light spread over the car park, whilst also minimising light spill. Figure 6, an elevation view across the site shows this.

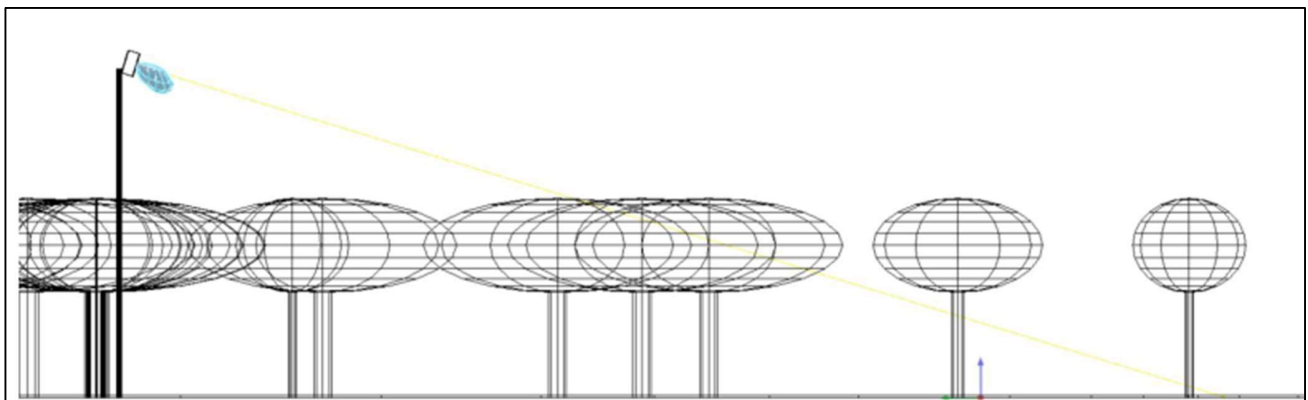

Figure 6. Column Elevation

Tilt Angles For Luminaires

Luminaire 1: -88.0

Luminaire 2: -89.0

Luminaire 3: -80.0

5. Calculations Explaining Lux Levels Achieved

The DIALux software has been used to model and calculate the lux levels throughout the site. The primary target was to ensure that the car park is illuminated to an average lux level of 15 lux, providing sufficient visibility for safety while maintaining compliance with light pollution standards and client requirements.

The site has been broken into various different calculation surfaces to better illustrate the lighting contours. The calculation surfaces have been divided as shown below.

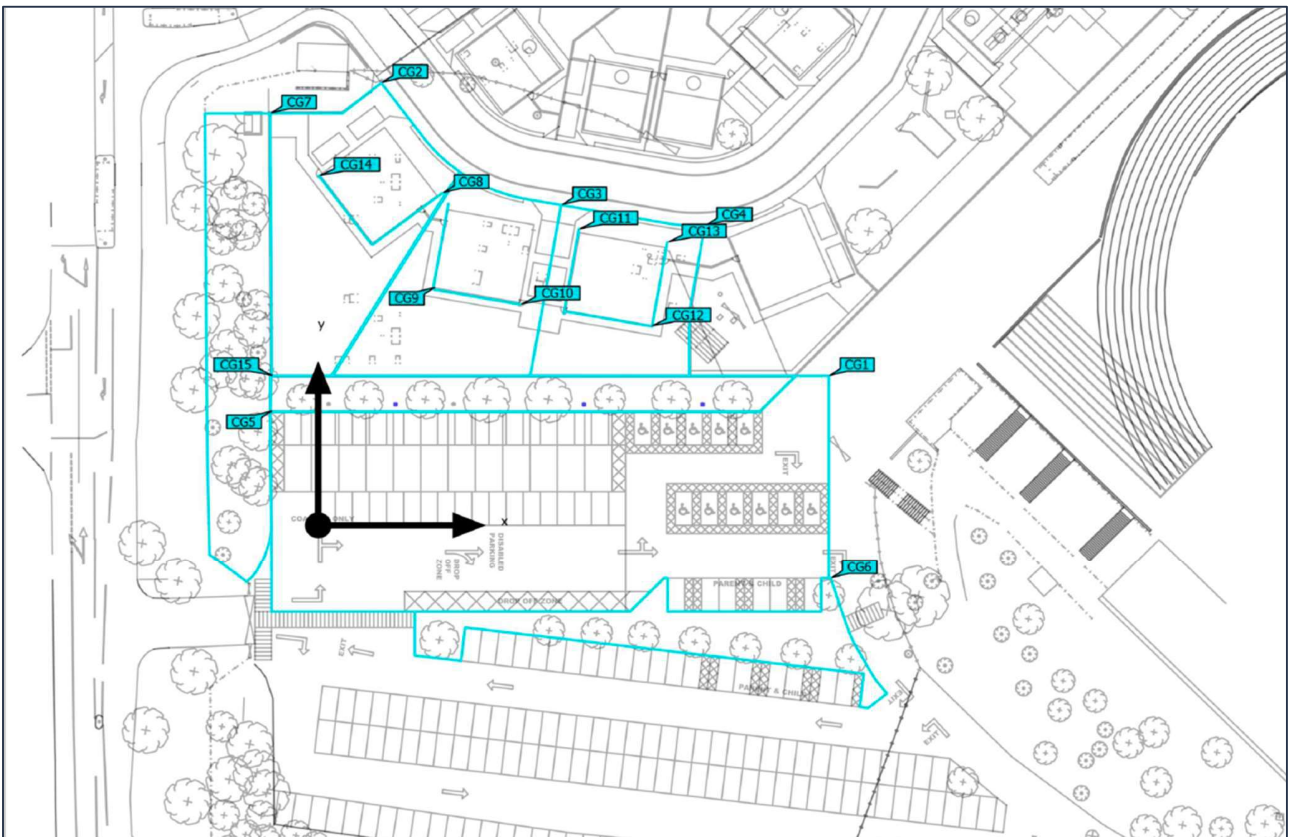

Figure 7. Overview of Isolated Calculation Areas

In addition to dividing the site into smaller calculation surfaces, some vertical calculation surfaces were also added to the neighbouring building faces to capture any light spill from the car park. As shown in figure 7. CG1-7 & 15 are horizontal calculation surfaces, whereas CG8-14 are vertical calculation surfaces. Table 1 below summarises the key results from the lighting simulation conducted in DIALux.

Calculation surfaces						
Properties	\bar{E}	E_{min}	E_{max}	$U_0 (g_1)$	g_2	Index
Car Park Perpendicular illuminance Height: 0.000 m	21.6 lx	5.44 lx	47.6 lx	0.25	0.11	CG1
house 3 Perpendicular illuminance Height: 0.050 m	0.007 lx	0.00 lx	0.052 lx	-	0.00	CG2
House 2 Perpendicular illuminance Height: 0.000 m	0.010 lx	0.00 lx	0.043 lx	0.00	0.00	CG3
House 1 Perpendicular illuminance Height: 0.000 m	0.013 lx	0.00 lx	0.086 lx	0.00	0.00	CG4
Tree Canopy North Perpendicular illuminance Height: 0.050 m	0.23 lx	0.003 lx	2.58 lx	0.013	0.001	CG5
Tree Canopy South Horizontal illuminance Height: 0.000 m	0.001 lx	0.00 lx	0.007 lx	-	-	CG6
Tree Canopy West Perpendicular illuminance Height: 0.050 m	2.11 lx	0.000 lx	10.3 lx	0.00	0.00	CG7
House 3 W2 Perpendicular illuminance Height: 3.573 m	0.060 lx	0.005 lx	0.20 lx	0.083	0.025	CG8
House 2 W2 Perpendicular illuminance Height: 3.500 m	0.030 lx	0.014 lx	0.063 lx	0.47	0.22	CG9
House 2 W1 Perpendicular illuminance Height: 3.573 m	0.22 lx	0.067 lx	0.42 lx	0.30	0.16	CG10
House 1 W2 Perpendicular illuminance Height: 3.573 m	0.028 lx	0.003 lx	0.076 lx	0.11	0.039	CG11

Table 1. Lighting Performance Summary: Average, Minimum, and Uniformity for Calculated Areas

House 1 W1 Perpendicular illuminance Height: 3.573 m	0.28 lx	0.11 lx	0.49 lx	0.39	0.22	CG12
House 1 W2 Perpendicular illuminance Height: 3.573 m	0.033 lx	0.004 lx	0.076 lx	0.12	0.053	CG13
House 3 W1 Perpendicular illuminance Height: 3.573 m	0.047 lx	0.002 lx	0.11 lx	0.043	0.018	CG14
Tree Canopy North Perpendicular illuminance Height: 3.000 m	0.37 lx	0.00 lx	7.58 lx	0.00	0.00	CG15
Utilisation profile: DIALux presetting (5.1.4.Standard (outdoor transportation area))						

Table 1 Continued. Lighting Performance Summary: Average, Minimum, and Uniformity for Calculated Areas

For additional details, please refer to the relevant lux level drawings on the following pages.

6. Lux Level Contours from DIALux Lighting Simulation

Car Park – CG1

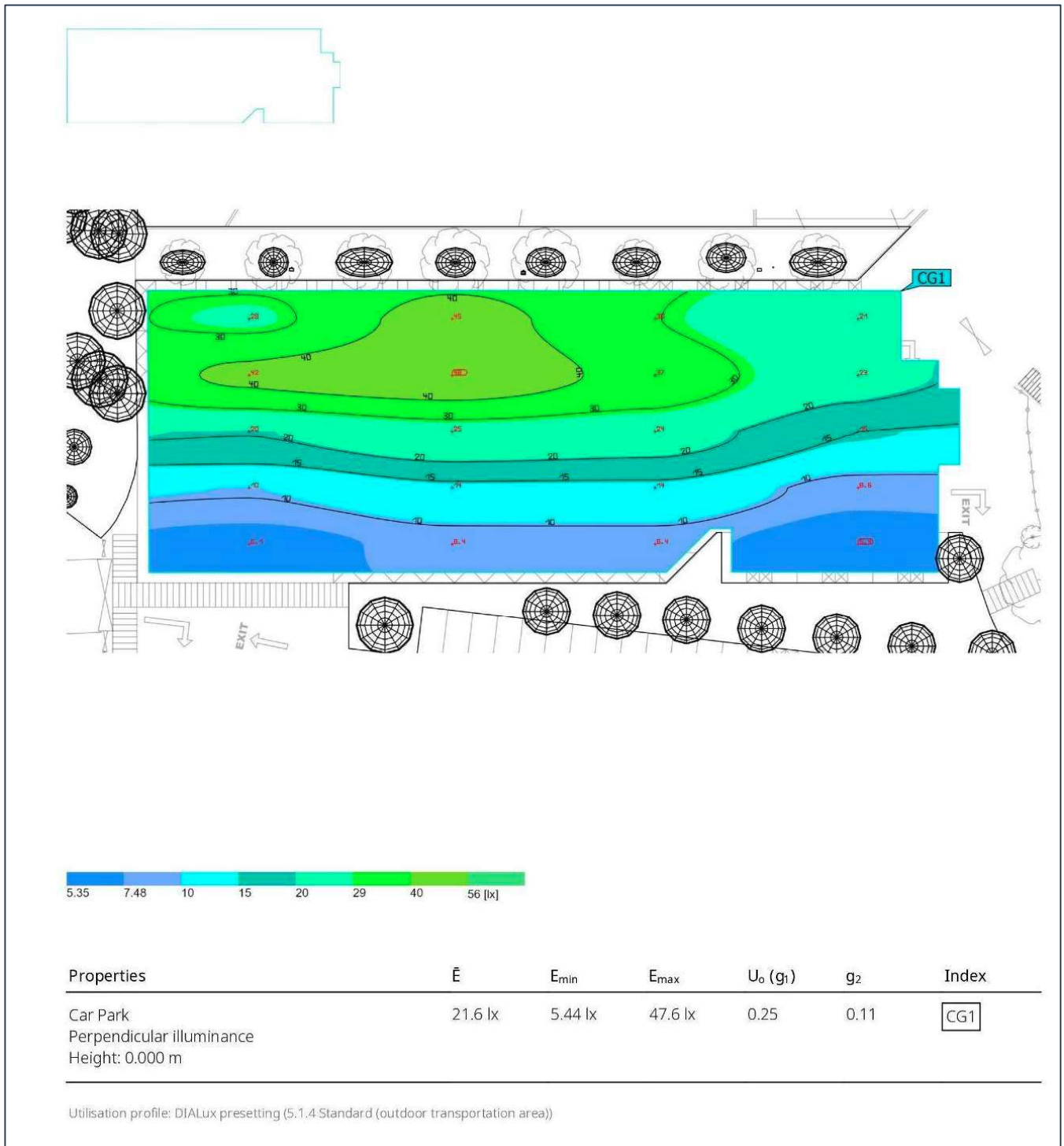

Figure 8. Detailed Lux Levels for CG1

The results from each calculation surface have been carefully analysed to ensure that the lighting levels meet the design criteria for safety, visibility, and compliance with local

regulations. The key metrics for each surface include the average lux level, the minimum lux level, and the uniformity ratio, which indicates the evenness of light distribution across the area.

CG1: Car Park Area

Avg: 21.6 lux

Min: 5.44 lux

UR(Min/Avg): 0.25

The car park achieves the recommended average lux level for vehicle and pedestrian safety for an outdoor car park with medium to light traffic. The uniformity ratio indicates the evenness of light distribution across the area. This has been minimised through careful placement of lighting columns and use of fittings with appropriate beam angles. Where excessive light spill was initially noted, additional measures, such as the use of baffles, ensure minimal light spill into adjacent residential areas. The light scene diagrams attached below show the lux levels across the site and in neighbouring residential areas.

House North West – CG2

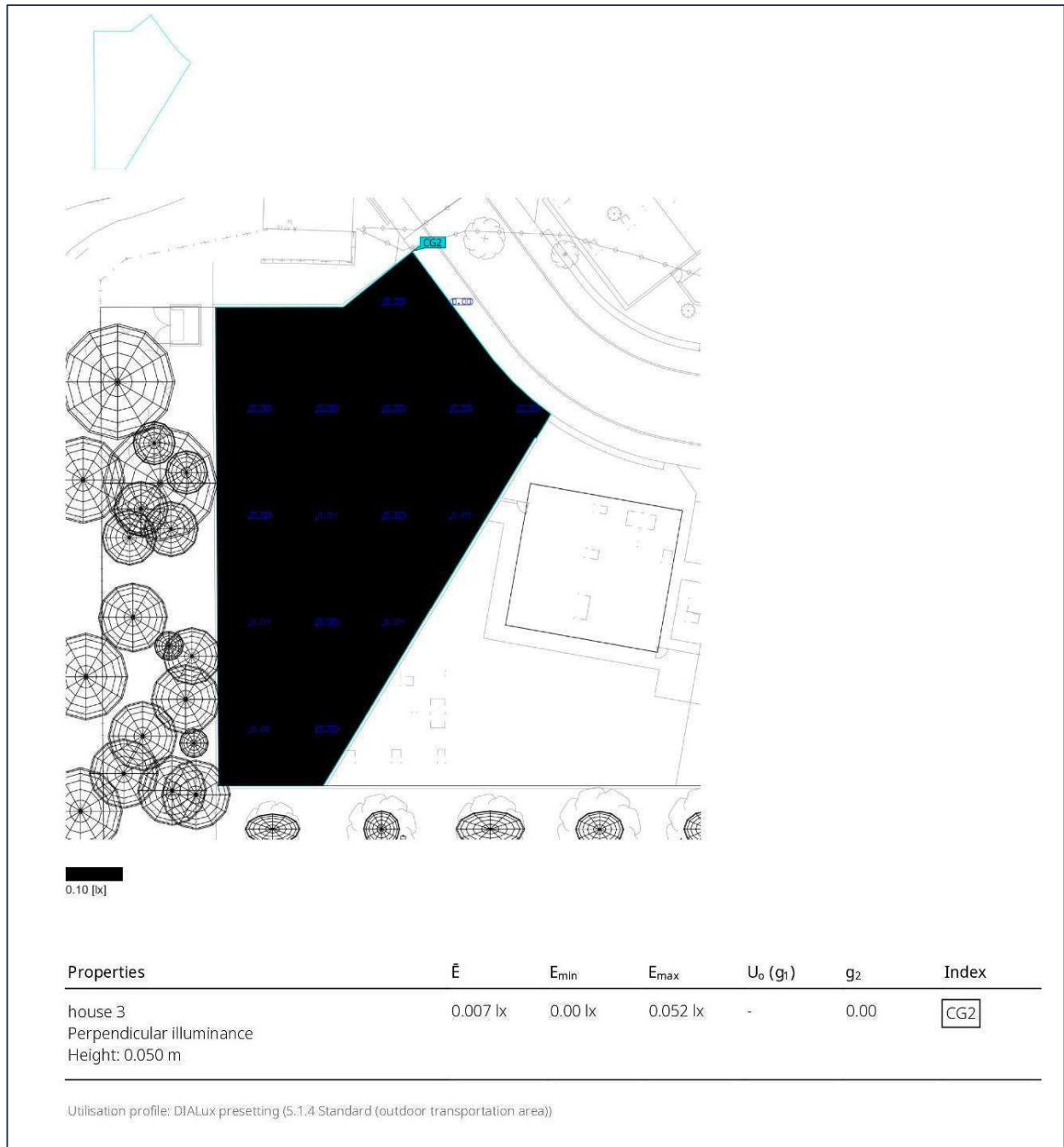

Figure 9. Detailed Lux Levels for CG2

CG2: House North West

Avg: 0.007 lux

Min: 0.00 lux

UR(Min/Avg): 0.00

House North - CG3

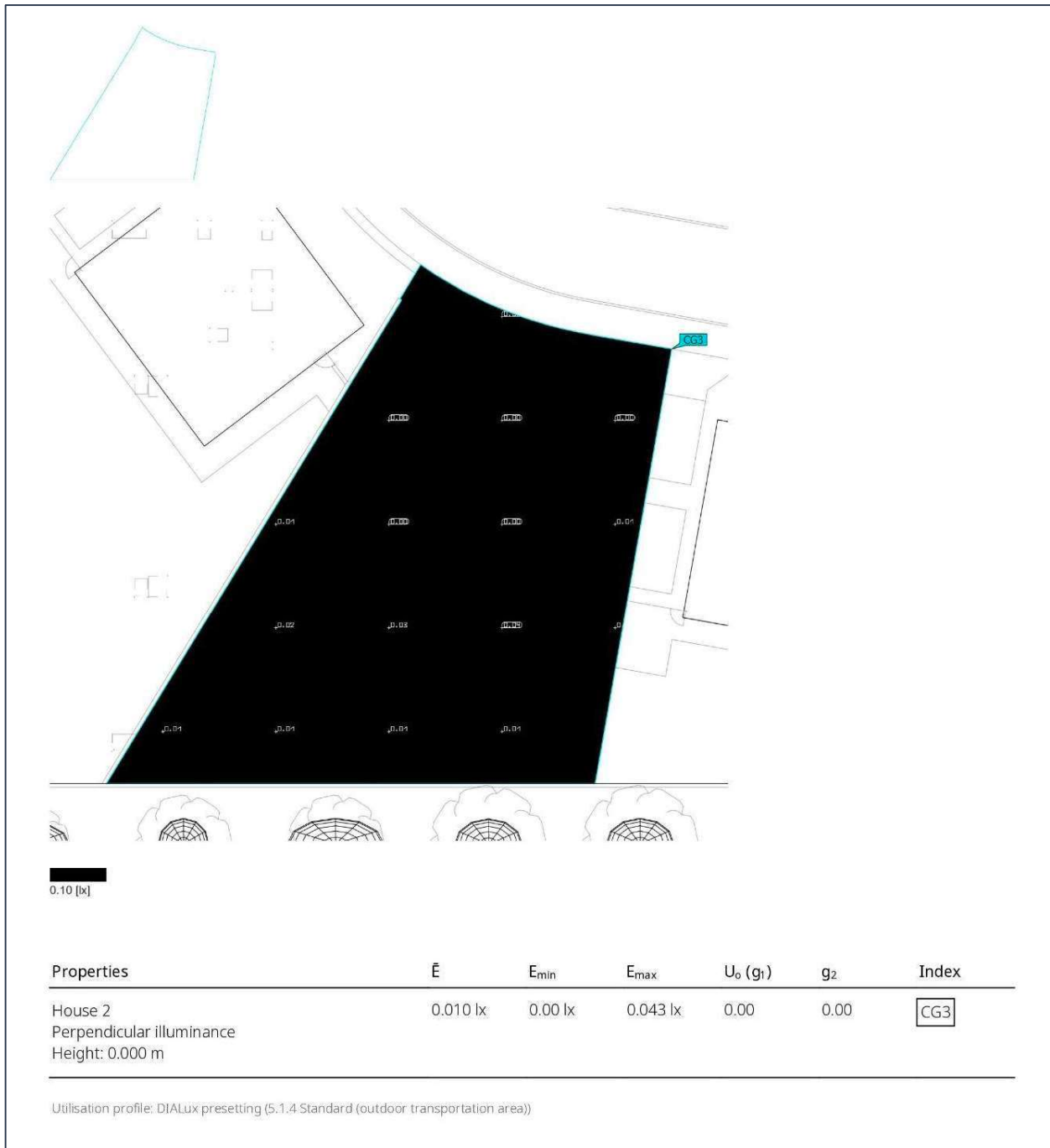

Figure 10. Detailed Lux Levels for CG3

CG3: House North
 Avg: 0.010 lux
 Min: 0.00 lux
 UR(Min/Avg): 0.00

House North East – CG4



Figure 11.Detailed Lux Levels for CG4

CG4: House North East

Avg: 0.013 lux

Min: 0.00 lux

UR(Min/Avg): 0.00

Tree Canopy North - CG5

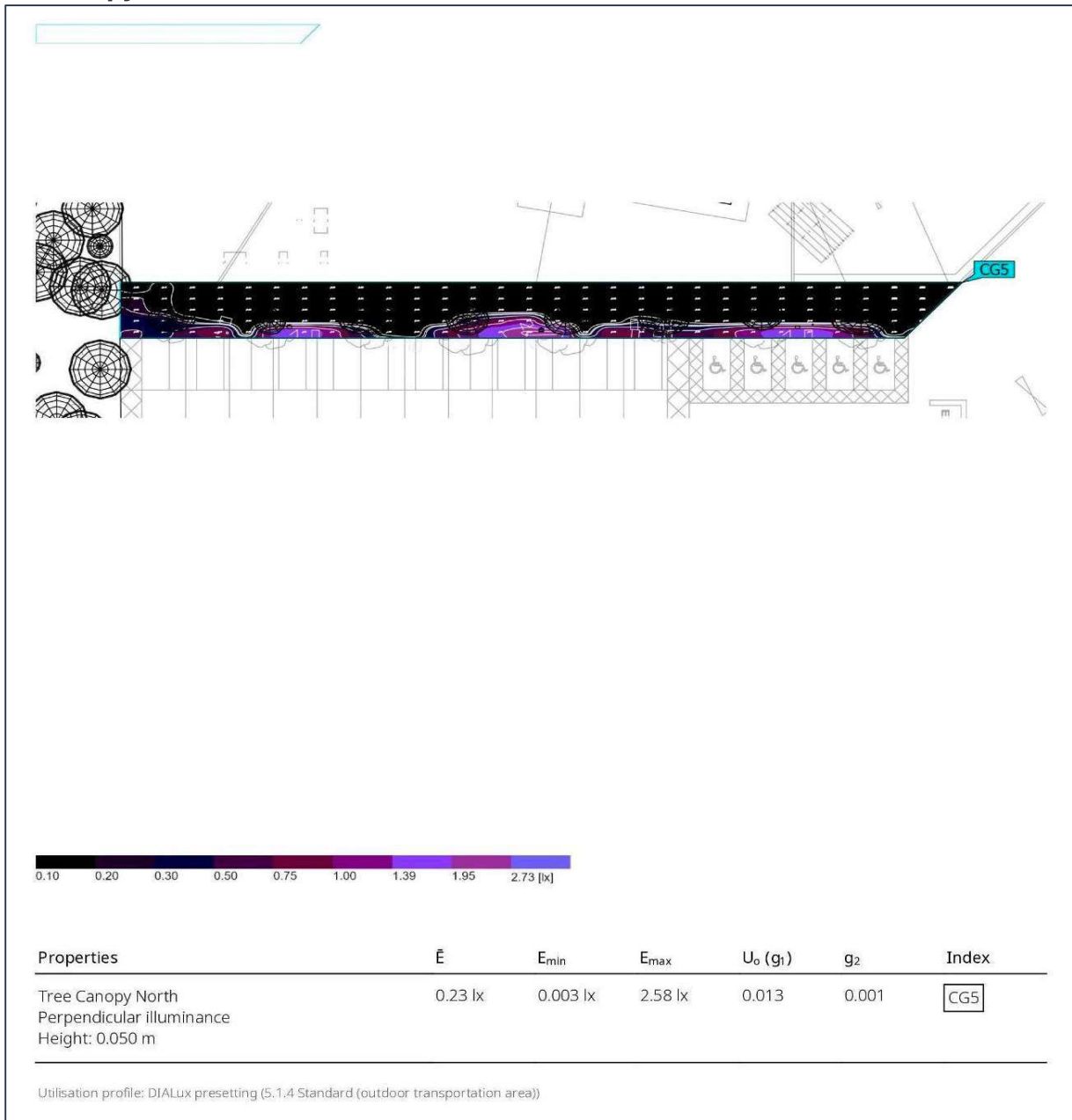

Figure 12. Detailed Lux Levels for CG5

CG5: Tree Canopy North

Avg: 0.23 lux

Min: 0.003 lux

UR(Min/Avg): 0.013

Tree Canopy South - CG6

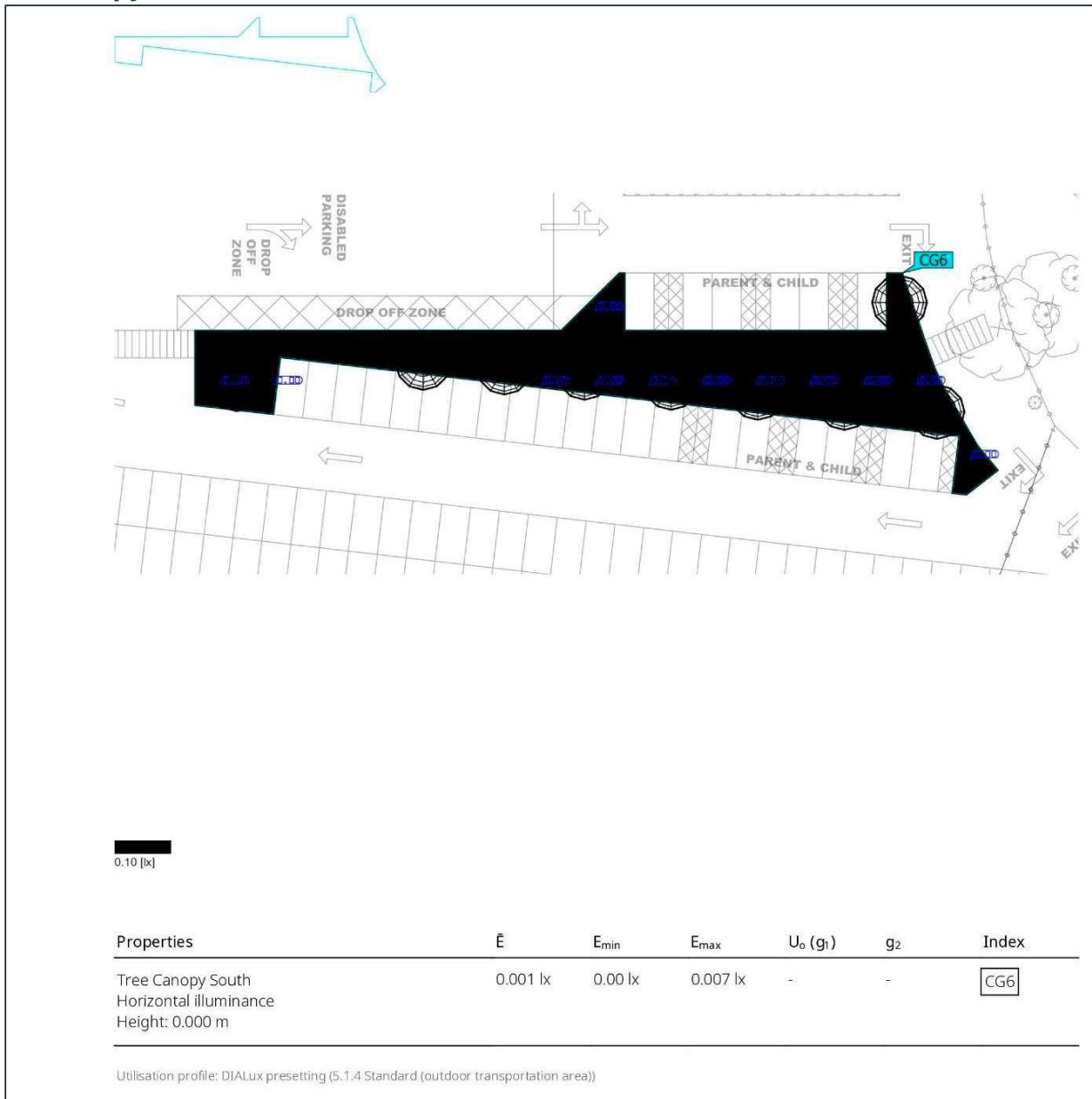

Figure 13. Detailed Lux Levels for CG6

CG6: Tree Canopy South

Avg: 0.001 lux

Min: 0.00 lux

UR(Min/Avg): 0.00

Tree Canopy West - CG7

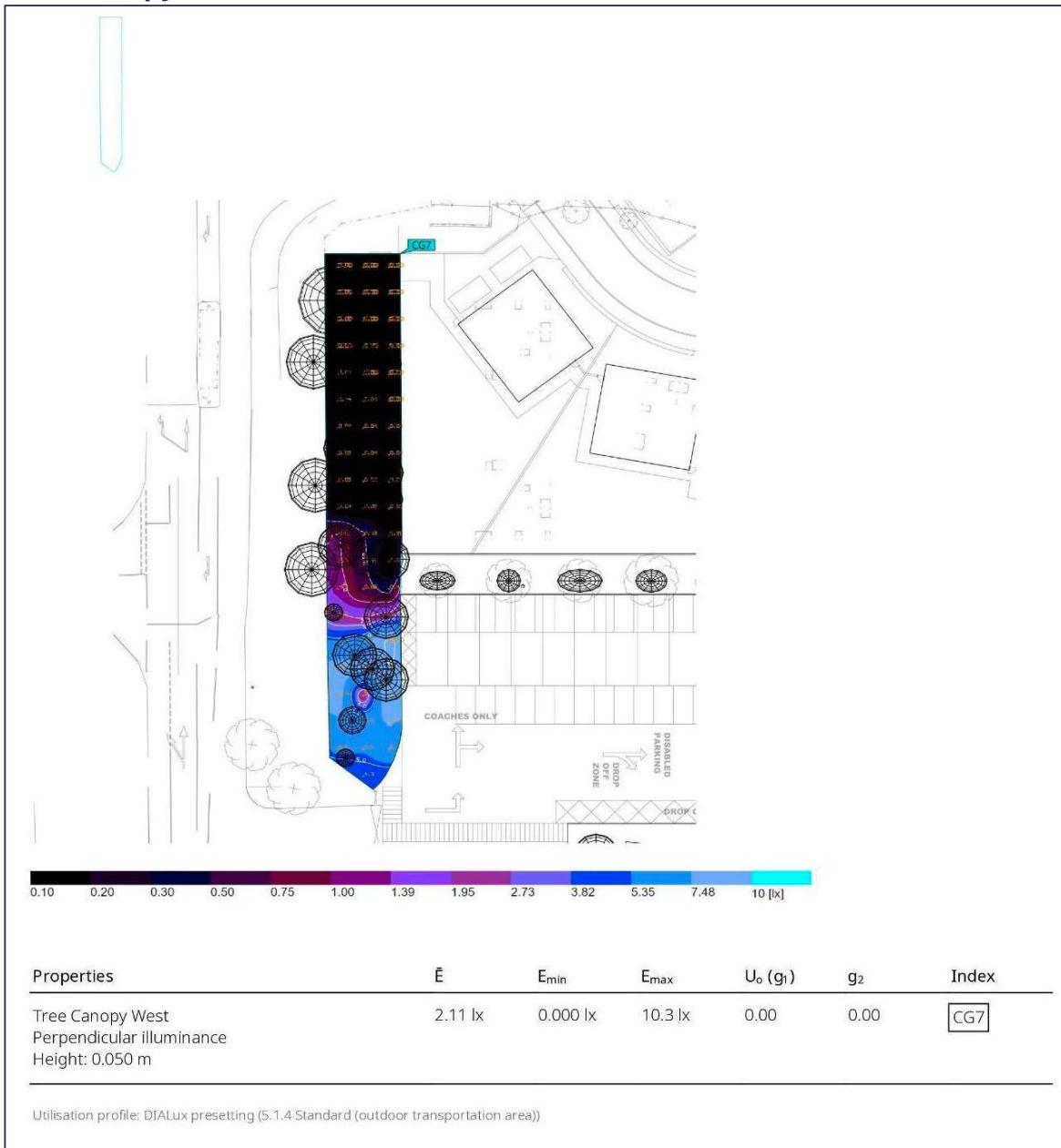

Figure 14. Detailed Lux Levels for CG7

CG7: Tree Canopy West

Avg: 2.11 lux

Min: 0.00 lux

UR(Min/Avg): 0.00

7. Light Spill Calculation on Neighbouring House Façades

The diagrams below show vertical calculation surfaces placed on the façades of the houses neighbouring the car park. These surfaces were used to assess the light spill from the car park onto the residential properties. By calculating the lux levels at these surfaces, we verified that the illumination levels comply with local regulations, particularly ensuring that the light levels do not exceed the maximum allowable lux at windows and sensitive areas, as outlined in the IPL guidelines. This analysis ensures minimal impact on the neighbouring residents.

House North West Wall 2 – CG8

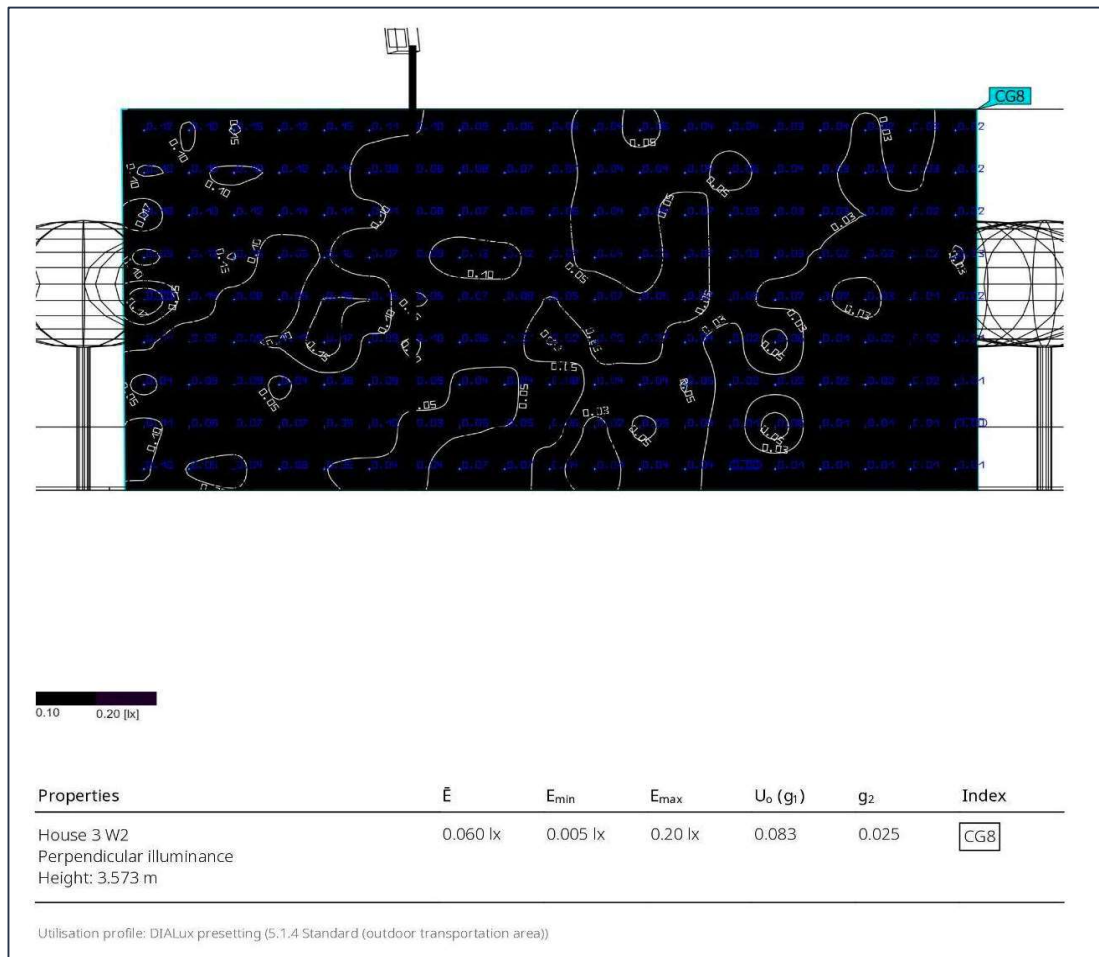

Figure 15. Detailed Lux Levels for CG8

CG8: House North West Wall 2
 Avg: 0.060 lux
 Min: 0.20 lux
 UR(Min/Avg): 0.083

House North Wall 2 – CG9

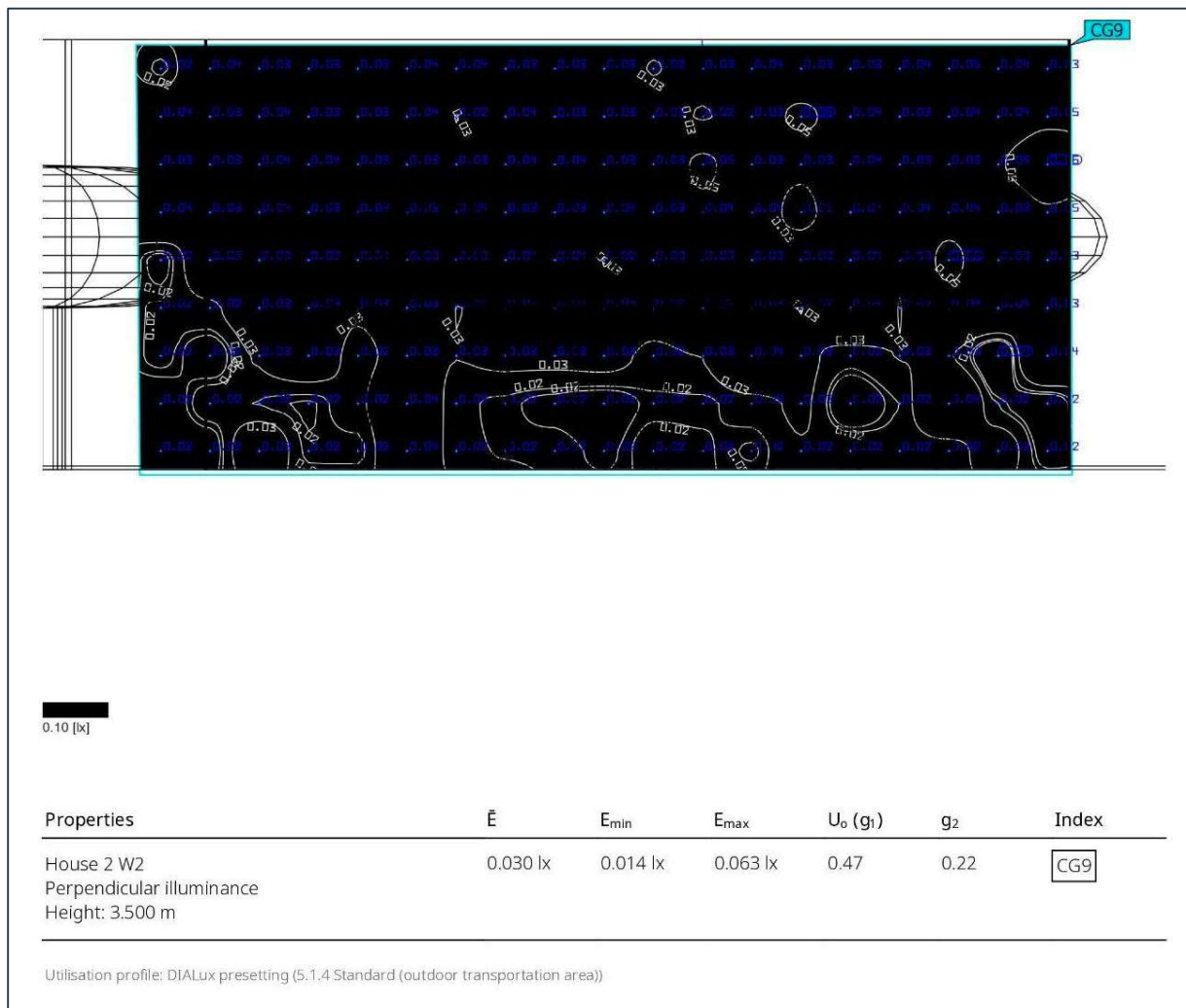

Figure 16. Detailed Lux Levels for CG9

CG9: House North Wall 2

Avg: 0.030 lux

Min: 0.014 lux

UR(Min/Avg): 0.47

House North Wall 1 - CG10

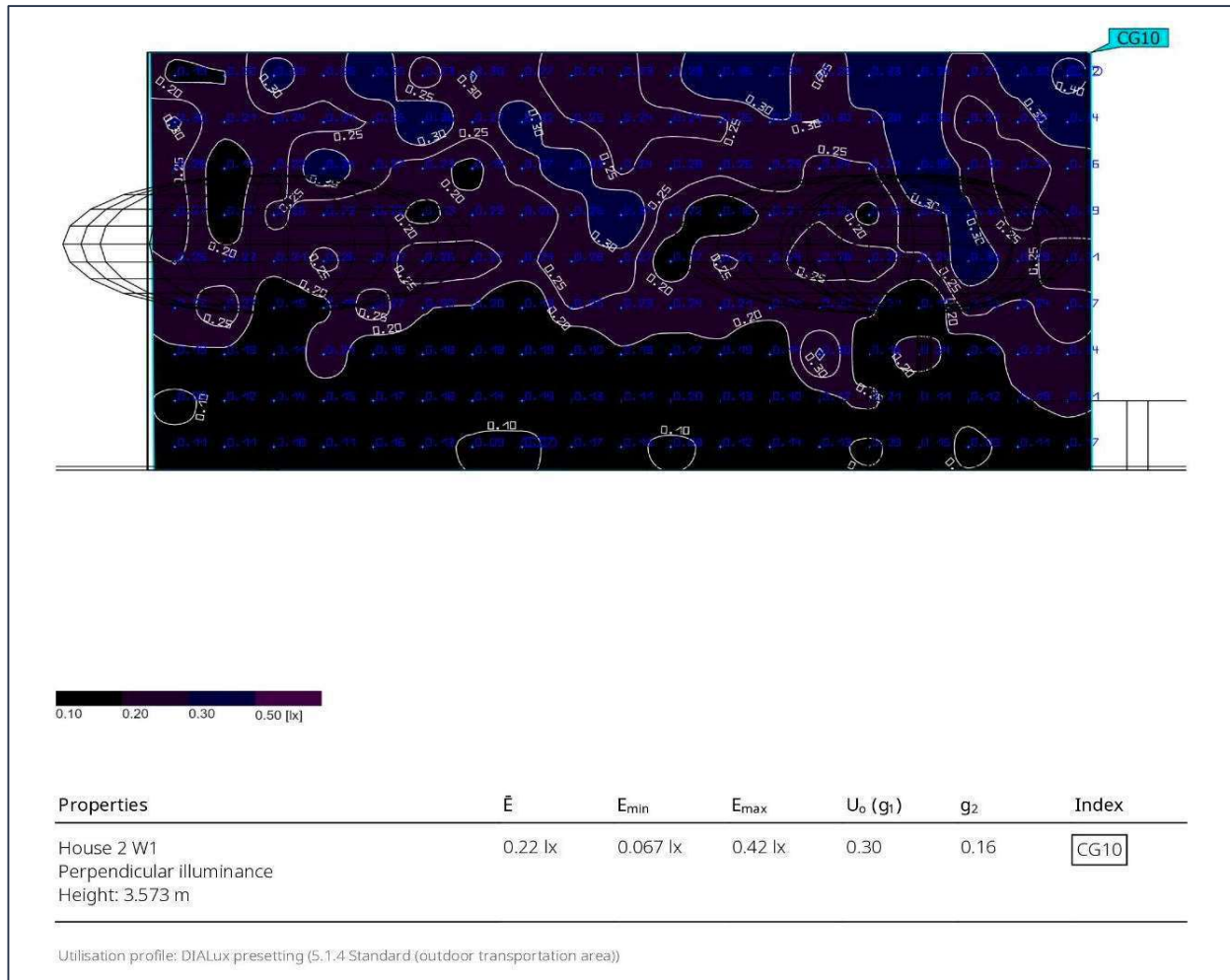

Figure 17. Detailed Lux Levels for CG10

CG10: House North Wall 1

Avg: 0.22 lux

Min: 0.0067 lux

UR(Min/Avg): 0.30

House North East Wall 2 – CG11



Figure 18. Detailed Lux Levels for CG11

CG11: House North East Wall 2

Avg: 0.028 lux

Min: 0.003 lux

UR(Min/Avg): 0.11

House North East Wall 1 – CG12

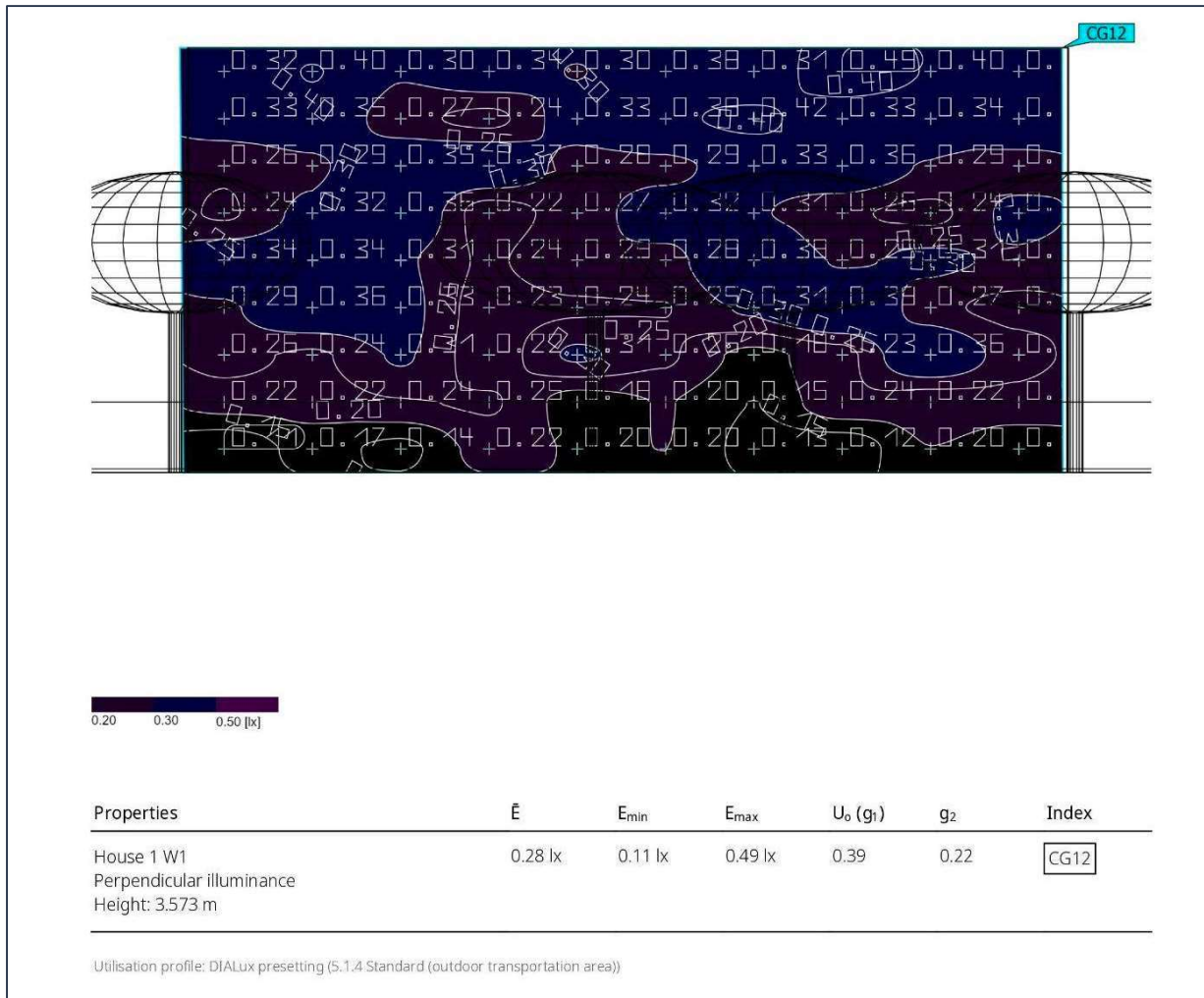

Figure 19. Detailed Lux Levels for CG12

CG12: House North East Wall 1

Avg: 0.28 lux

Min: 0.11 lux

UR(Min/Avg): 0.39

House North East Wall 3 – CG13

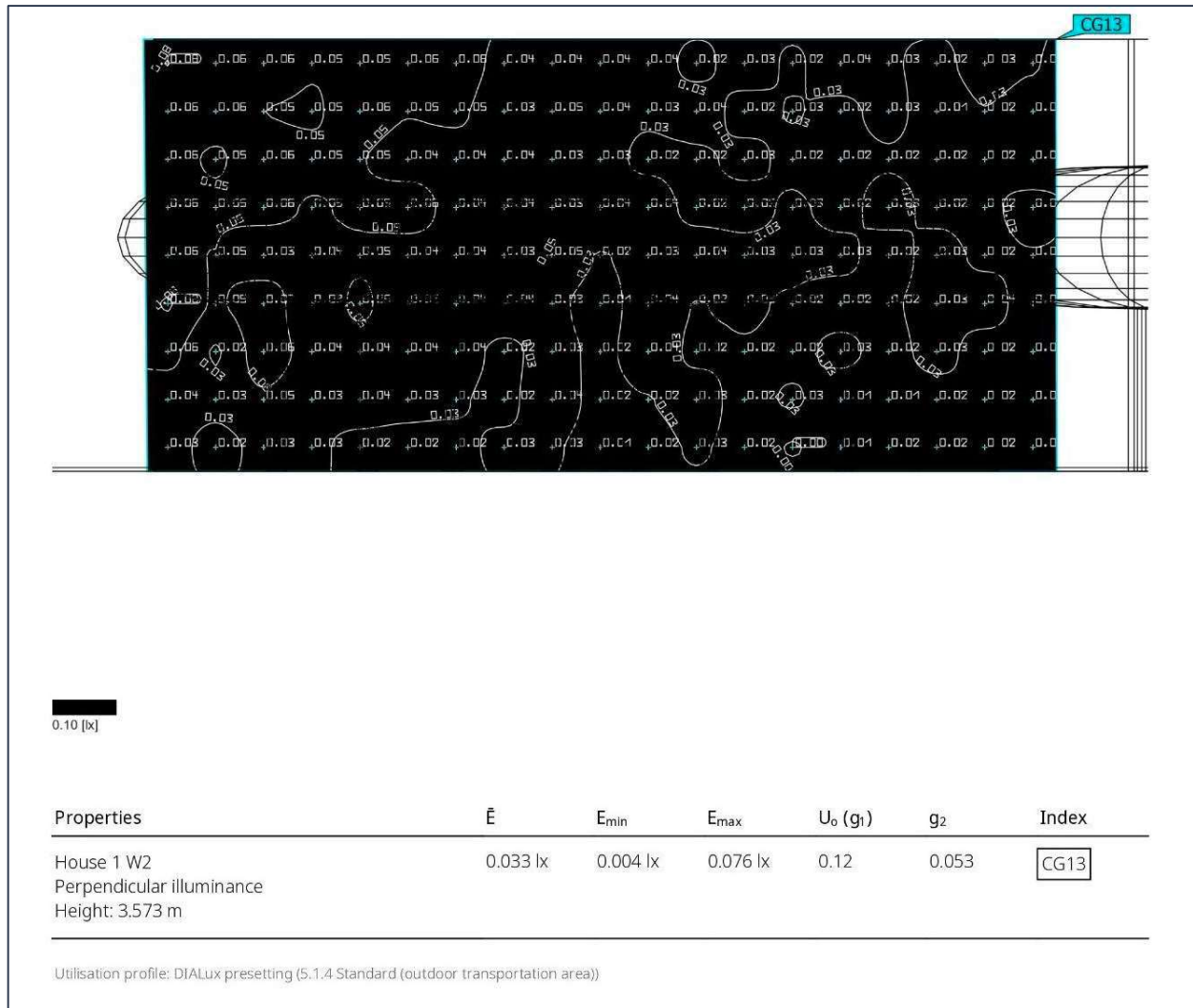

Figure 20. Detailed Lux Levels for CG13

CG13: House North East wall 3

Avg: 0.033 lux

Min: 0.004 lux

UR(Min/Avg): 0.12

House North West Wall 1 – CG14



Figure 21. Detailed Lux Levels for CG14

CG14: House North West Wall 1

Avg: 0.047 lux

Min: 0.002 lux

UR(Min/Avg): 0.043

8. Compliance with Bat Regulations

As part of the environmental considerations, the lighting design complies with bat conservation guidelines, ensuring minimal disruption to local wildlife. Key compliance points include:

- Warm light temperatures ([X K, typically less than 3000K for bat compliance]) to reduce the attraction of insects and avoid disturbing nocturnal wildlife.
- Directional lighting that limits upward light spill and minimises intrusion into natural habitats.
- Baffles and shields used on fixtures to reduce light spill into areas where bats are likely to forage or roost, particularly near the north tree canopy.

In addition illuminance contour plots for areas where bats are expected have been produced in line with the guidelines set in the IPL GN08.

The lighting scheme has been designed with reference to the Bat Conservation Trust's Guidance Notes for Lighting and aims to protect the local bat populations while ensuring the functional requirements of the car parks are met.

9. Conclusion

In conclusion, the proposed lighting design for the land to the rear of [REDACTED] meets the necessary safety and visibility requirements while adhering to the strict guidelines regarding light pollution and environmental protection.

The lux levels across the site, including in adjacent residential properties, comply with IPL recommendations. Additionally, the design takes into account the protection of local wildlife, particularly bats, by utilising appropriate light fittings and temperature settings. We believe the proposed lighting solution is compliant with local regulations and provides an effective balance between safety, efficiency, and environmental responsibility.